



APPLICATION

Filtration of all liquids. For installation into suction or pressure pipework to protect downstream equipment (pumps, bearings, heat exchangers, valves, pipework etc.) against contamination or accumulation of mud.

OPERATION

The filter is completely maintenance-free except for checking of the seals and cleaning of filter elements. The pressure drop indicates the contamination degree of the filter. To clean the filter element, the installation must be shut-down or the filter isolated.

CLEANING

Depressurize the filter chamber by means of the venting screw. Lift the housing cover, remove the filter element, rinse it with the cleaning fluid, e.g. BOLL-CLEAN 2000, and clean it by compressed air.

(See operating instructions 'filter element cleaning').

TECHNICAL CHARACTERISTICS

- Filter housing made of cast ductile iron (DN 25 to DN 80) or cast stainless steel (DN 25 and DN 50)
- Certified according to AD 2000, PED/DGRL97/23/EG and ASME SECT. VIII DIV.1
- Flanged connections according to DIN, ANSI, JIS
- Filter elements: **star-pleated 1** element or **basket 2** element, optionally as disposable element
- Grade of filtration: 10 micron to 5 mm
- Operating temperature: -10°C to 160°C

ACCESSORIES

- Differential pressure indicator optical/optoelectrical

BOLLFILTER Simplex TYPE 1.12.2

with flanged connections DN 25 – DN 80
optionally with integrated steam heating



- Cover safety device
- Magnetic bar inside the filter element
- Steam heating
- Bottom fastening for filter size DN 65/80

ADVANTAGES

- Minimal pressure losses
- Most compact construction
- Minimal number of components
- Easy cover fastening with only two screws

Pressure stages / Dimensioning

In- / Outlet	DN 25	DN 32	DN 40	DN 50	DN 65	DN 80
Cast ductile iron	PN 40	PN 40	PN 40	PN 40	PN 40	PN 40
Cast stainless steel	PN 32	---	---	PN 32	---	---
Volume flow at						
Δp clean 0.1 bar; Oil 40 cS	5 m ³ /h	9 m ³ /h	14 m ³ /h	21 m ³ /h	35 m ³ /h	53 m ³ /h
Grade of filtration 50 μ m	83 l/min	150 l/min	233 l/min	350 l/min	583 l/min	883 l/min

THE DETAILS

Z107393 - Type 1.12.2

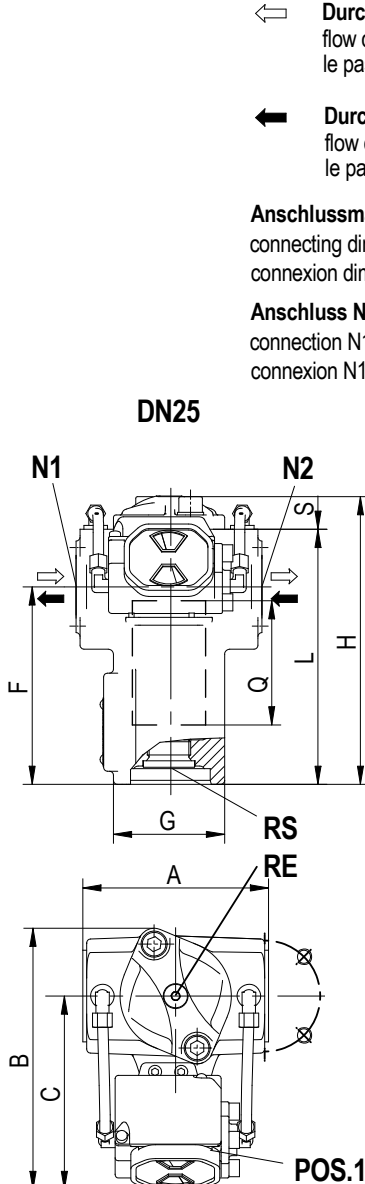
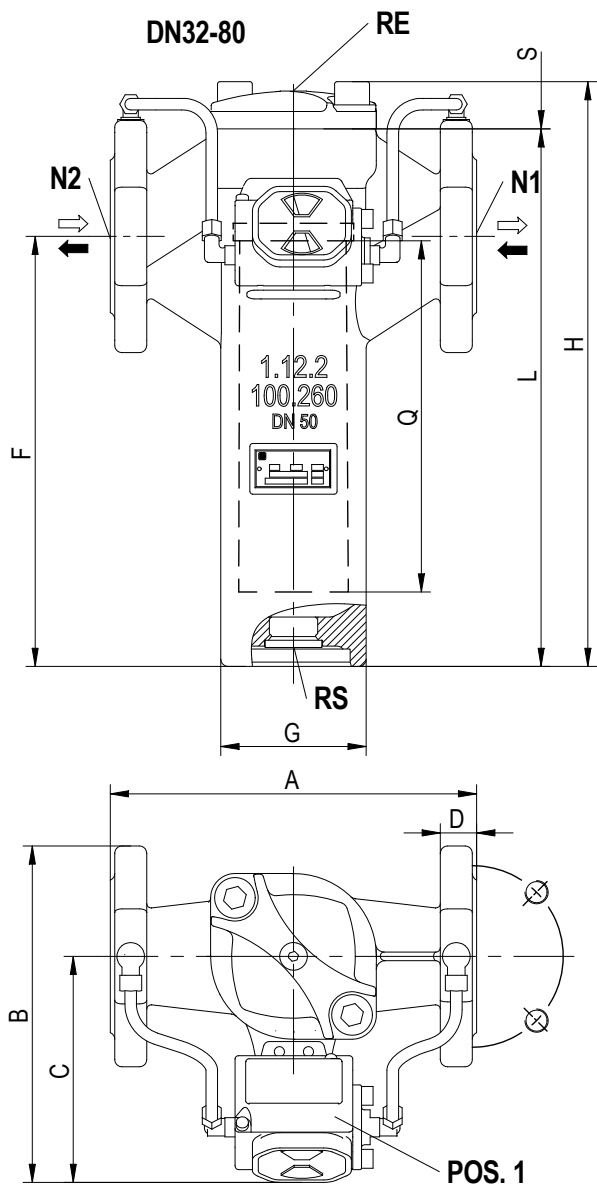

← **Durchflussrichtung bei Korbsiebelelementen**
flow direction with basket elements
le passage avec des paniers à corbeille

← **Durchflussrichtung bei Sternsiebelelementen**
flow direction with star-pleated elements
le passage avec des panier étoile

Anschlussmaße N1/N2 nach DIN2501 / ANSI B16.5 / JIS 40K
connecting dim. N1/N2 acc. to DIN2501 / ANSI B16.5 / JIS 40K
connexion dim. N1/N2 d'après DIN2501 / ANSI B16.5 / JIS 40K

Anschluss N1/N2 Schraubenlöcher mit Gewinde
connection N1/N2 drilling template with thread
connexion N1/N2 trous avec filetage

RE Entlüftung G1/4
vent
désaération

RS Entleerung G1
drain
vidange

S Ausbau Filterelement
filter element removal
démontage du panier

Gehäuse gegossen
housing casted
corps moulé

Allgemeintoleranzen DIN ISO 2768-M
general tolerance
tolérances générales

auf Wunsch, optional, sur demande

POS.1 Differenzdruckanzeiger
differential pressure indicator
indicateur de différence de pression

Bestellbeispiel Typ G Q DN
ordering example 1.12.2 100 260 50
exemple de commande

G	Q	DN N1 / N2	A	B	C	D	H	F	L	S	Volumen dm ³	Gewicht kg
85	95	25	142	200	148	18	220	151	195	170	0,8	8
85	145	32	182	202	152	28	268	196	242	220	1,0	10
100	210	40	218	216	164	33	356	264	323	300	2,0	15
100	260	50	252	232	156	25	403	296	370	350	2,5	19
140	406	65	312	267	179	33	586	454	550	530	7,8	39
155	508	80	332	283	189	33	698	553	662	650	11,3	49

subject to alteration
single filter

Änderungen vorbehalten!
Einfachfilter Typ 1.12.2

modifications réservées
filtre simple

